



CELETTE®

CAR LIFE SOLUTIONS

GAMME MARBRE

SEVENNE XL



Marbre mobile pour la réparation et le contrôle des véhicules
Extended length mobile bench to check and repair large vehicles

* SVN09XL.3112

www.celette.com



CELETTE®

CAR LIFE SOLUTIONS

BENCH RANGE

SEVENNE XL

Marbre sur roues dédié à la réparation des utilitaires

La grande mobilité de ce marbre permet une mise en place sous un pont 2 colonnes ou bien de libérer l'espace de travail lorsque celui-ci n'est pas utilisé. Sa longueur de 5.8M est parfaitement adaptée aux utilitaires. Sa ceinture universelle permet la fixation rapide ou le déplacement sans effort des pinces d'ancrage, roues, timon de manœuvre et support multifonction.

Extended length Bench on wheels designed to repair larger commercial vehicles

The important feature of this bench allows positioning under a 2 post lift for loading, or easily moved between work bays. The 5.8 M (19 Feet) length is suitable for light truck and commercial vehicles. The universal peripheral frame enables the quick anchoring or adjustment of the clamps, wheels, transport handle or multi-function support.

Références Part Number	Designation	Description
SVN09XL.3112	Marbre + 4 pinces d'ancrage + Equerre + Servante de rangement (cf. composition page 1)	Bench + 4 anchoring clamps + Pulling unit + Storage trolley (cf kit page 1)
9121.543	Vipère	Vipère pulling unit
9121.523	Support multifonction	Multi-use support
9121.533	Timon de manoeuvre	Transport Handle
SC.40014	Coffret hydraulique	Storage case for hydraulic components
CSK.15111	Kit pour tractions	Hydraulic Pulling Kit

Options

Vipère

Vipère pulling unit



9121.543

Kit pour tractions

Hydraulic Pulling Kit



CSK.15111

Timon de manoeuvre

Transport Handle



9121.533

Support multifonction

Multi-function



9121.523

Coffret hydraulique

Storage case for hydraulic components



SC.40014

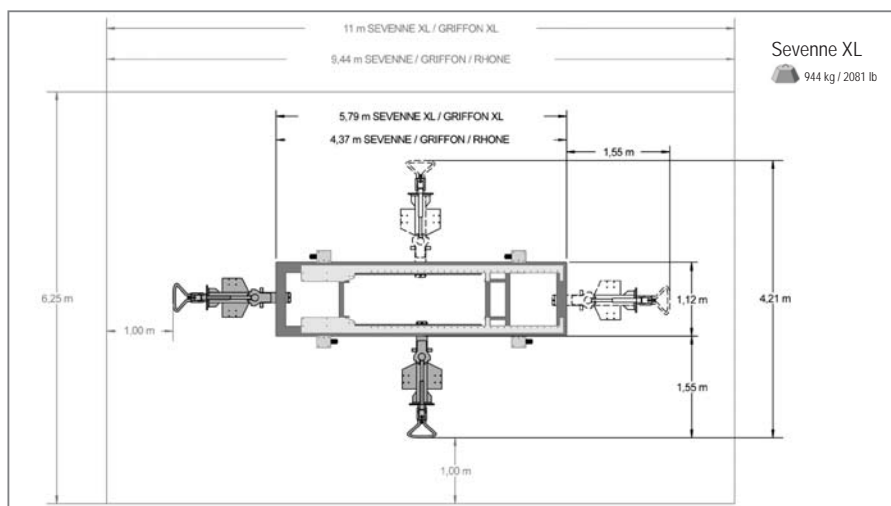

Doc. 419F-GB/RO 02/10

